

Reference Diagram

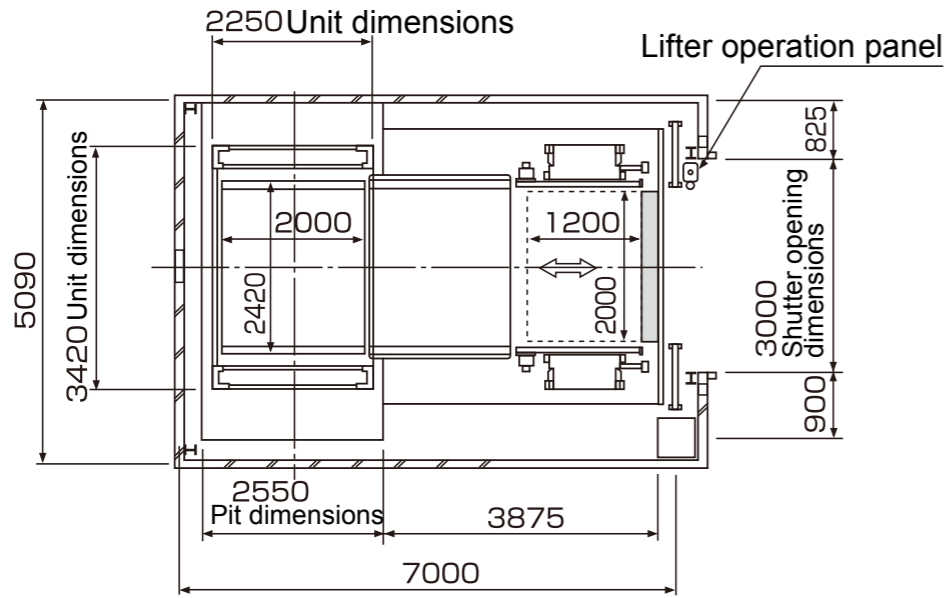

[1F floor plan]

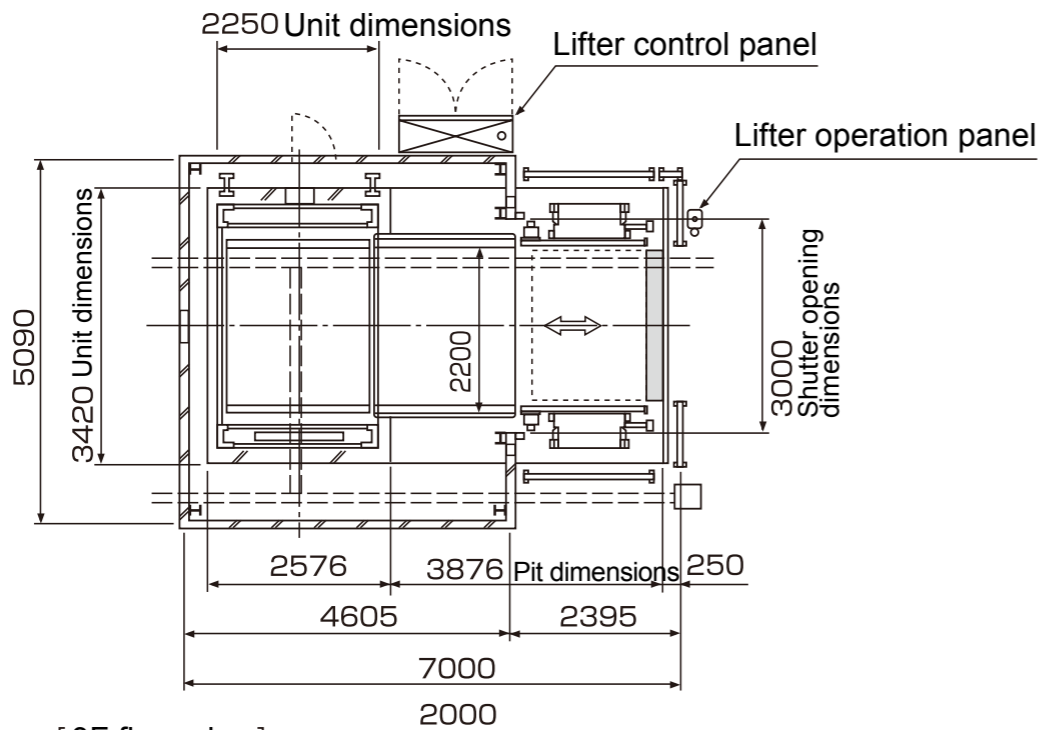

[3F floor plan]

